

Product End-of-Life Instructions

Product Range: Desking System and AL Panel System

List of Models Applicable

- Synergy
 - Perform
 - Colours
 - Collabrate
 - Connect
 - AL 60 Panel System
- Desking System

Purpose:

The product family must be disposed according to the legislation of the country. This document is intended for use by end of life recyclers or treatment facilities. It provides the basic information to assure an appropriate end of life treatment for the components and materials of the product.



Desking System



Panel System

Operations Recommended for End Of Life of the Product

There are several steps to process the products at the end of life so as to recover components or Materials

The components of the products that optimize the recycling performances are listed, identified and located hereunder.

Disassembly Instruction – Desking System

1. Remove the Glass Screen from the Product as per the instruction provided. Place the screen into the appropriate recycling waste stream. (Glass)
2. Disassemble the AI Screen Holders as per the instructions provided and place them into the appropriate recycling waste stream. (Metal - Aluminum)
3. Dismantle Table Top as per work disassembly work instruction and place them into the appropriate recycling waste stream (Wood)
4. Disassemble cross beams and vertical legs as per work instruction and place them into the appropriate recycling waste stream (Metal – Mild steel)

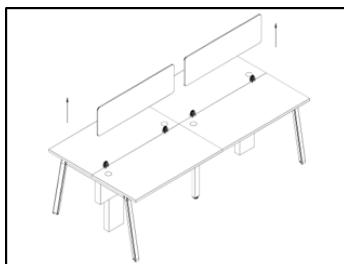

SCREEN REMOVAL

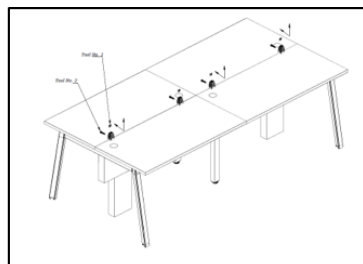

SCREEN HOLDER SCREWS REMOVE

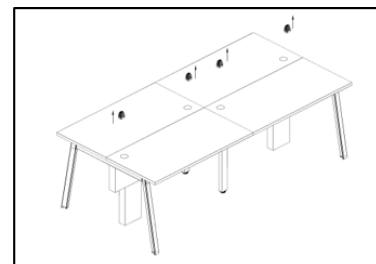

SCREEN HOLDER REMOVE

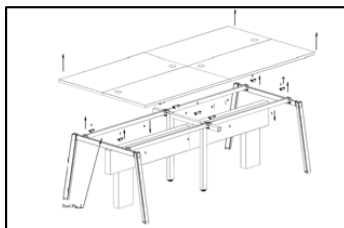
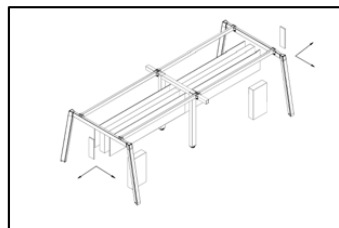
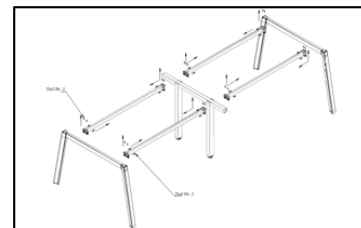

TABLE TOP & SPACER REMOVAL



RACEWAY/SIDE TRIM REMOVAL



CROSS BEAM & LEG ASSEMBLY REMOVAL

Disassembly Instruction – Panel System

1. Remove the Table Top and Gable End from the Product as per the instruction provided. Place the screen into the appropriate recycling waste stream. (Wood)
2. Disassemble the Al panel system as per the instructions provided and place them into the appropriate recycling waste stream. (Metal - Aluminum)
3. Dismantle Aluminum trims as per work disassembly work instruction and place them into the appropriate recycling waste stream (Metal – Aluminum)
4. Dismantle Metal Loose components as per work instruction and place them into the appropriate recycling waste stream (Metal - Steel)

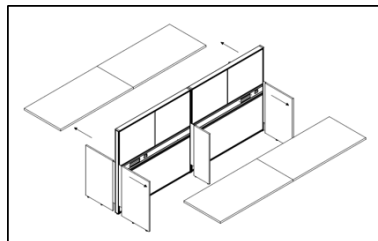

REMOVE TABLE TOP

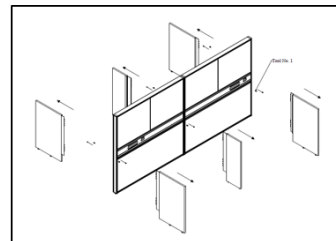

REMOVE GABLE END

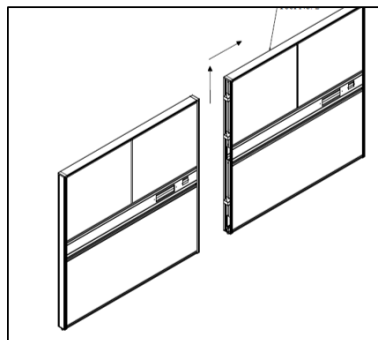

REMOVE MAIN SPINE

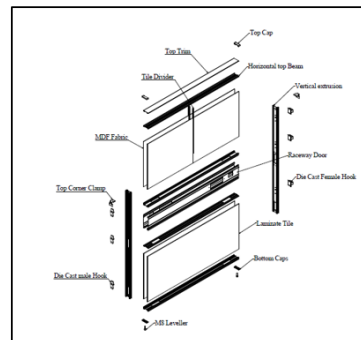

REMOVE CHILD COMPONENTS

Recycling/scrap agencies have been identified and intimated for assistance.
The list is appended below:

RECYCLING FACILITIES IN INDIA				
FEATHERLITE LOCATION	COMPANY	ADDRESS	NEAREST (RECYCLING) SCRAP FACILITY & ADDRESS	MATERIAL
SOUTH				
Secunderabad	Choice Marketing Company (Franchisee)	#100, Rashtrapathi Road, SECUNDERABAD 500 003 Andra Pradesh	Kohinoor Traders shop no 8-3-168/h/3,sanman hotel lane erragadda, Hyerabad-500018 Farooq G.S + (91)-40-67110964	PLASTIC
Vijayawada	Colour Care Chandralok (Dealer)	Commercial Complex, K.P. Nagar, Near Stella College VIJAYAWADA 520 008 Andra Pradesh	Expert Metals Shop No 302, Venus enclave Enigineer colony, Yellareddy guda, Hyderabad,A.P,India Shaik Rafi + (91)-9866017873, +91-40-23731627	WOOD
Visakhapatnam	The Decograph Interiors (Dealer)	Udyog Bhavan Block 'A', Vuda Complex Siripuram, VISAKHAPATNAM 530 003 Andra Pradesh	Baba Iron Scrap Merchant 9-61-25, Brp Road, Islampet, Vijayawada - 520001 (91)-(866)-2522654	IRON
WEST				
Goa	Newways Office Works (Dealer)	Opp. Army House, Altinho, Panjim, GOA - 403 001	Balaji Scrap Serve No 203/1 Mushirwada Village, Kolval Village, Goa Head Post Office, Goa - 403001 Mr Bala Naidu/Mr Ghulam Gaus + (91)-9323022005	METALS
Mumbai	Featherlite Collections	Nirlon House, West Wing, 1st Floor, 254-B, Dr. Annie Besant Road, Worli, MUMBAI 400 030	Victor Plastics No.9/5, Royapuram,Kasimedu Signal,Jeevarathinam Salai, Chennai, Chennai-600011 Mr Fedrick V - 91-44-32560349, 91-98844906	PLASTICS & WOOD
NORTH				
New Delhi	Supertech (India) Pvt. Ltd., Franchisee	K-1/116, EPDP, Chitranjan Park, NEW DELHI 110 019	Global Steel Trading Company 317b Mukand Nagar, Industrial Area,Ghariabad,Ghariabad-201001 (Also serves Delhi) Mr Huzer Akhtar + (91)-11-66242696	ALL METALS

Prepared By:

Dileep M

Approved By:

Shrikant